

neue Version / new version

Bestehende Version / existing version

A

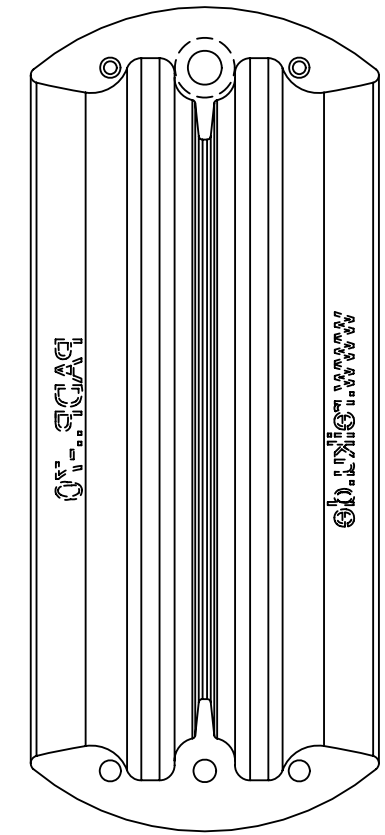
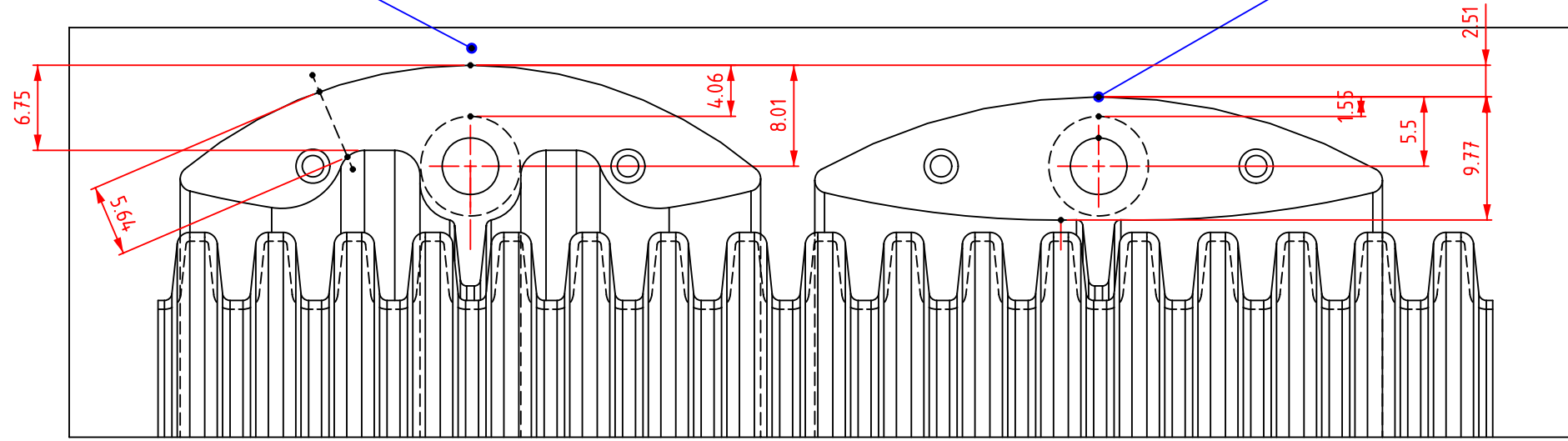

A

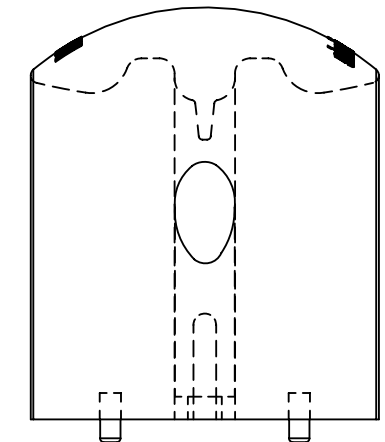
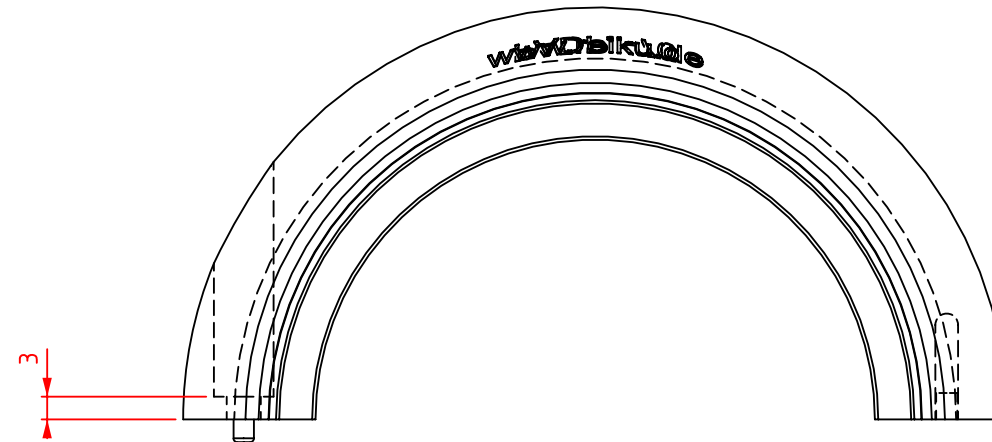
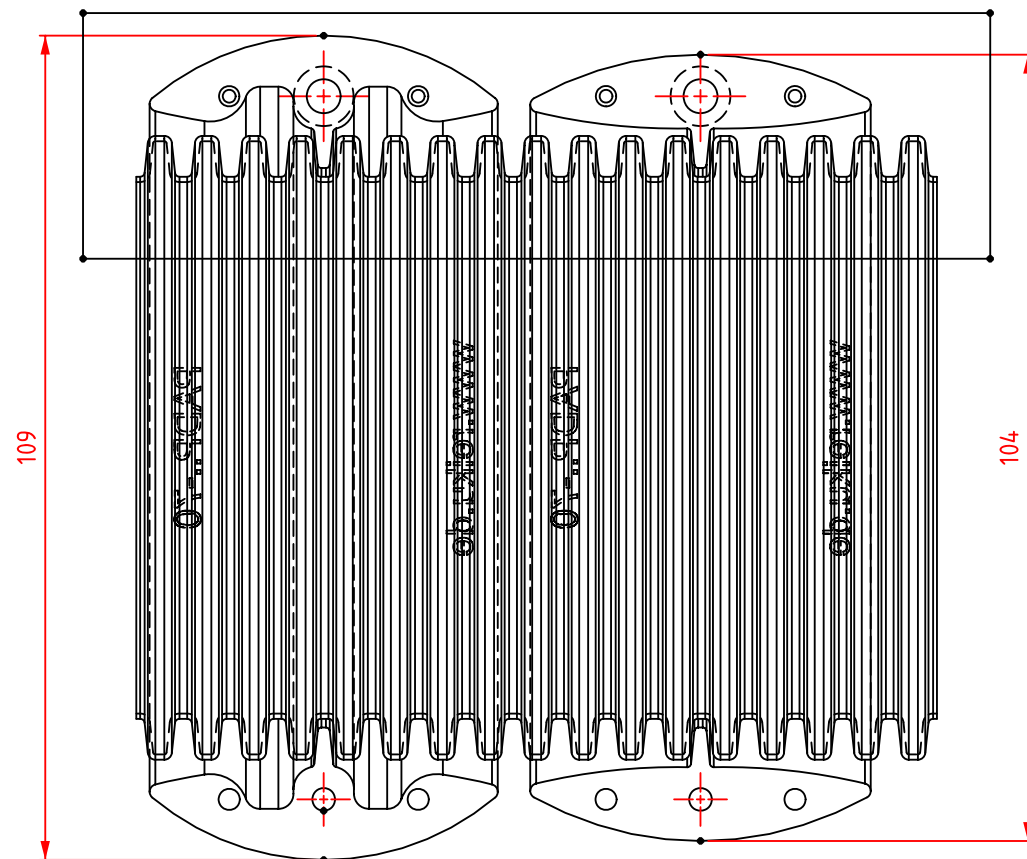

(Verwendungsbereich)	(Zul. Abw.)	(Oberfl.)	Maßstab	1:1	Gewicht	54.39g
-	DIN 16742		Werkstoff	PA6 GF30		
-	Tab. 1, Reihe 2		PADPB-70-neue-Kontur			
	Datum	Name				
	Bear. 07/07/2014	A.Tatai				
	Gepr.	N.Schäfer				
	Norm		Entwurf			
			REIKU GmbH			Blatt
			www.reiku.de			Bl.
Zust.	Änderung	Datum	Name			